

# Hydraulic excavators

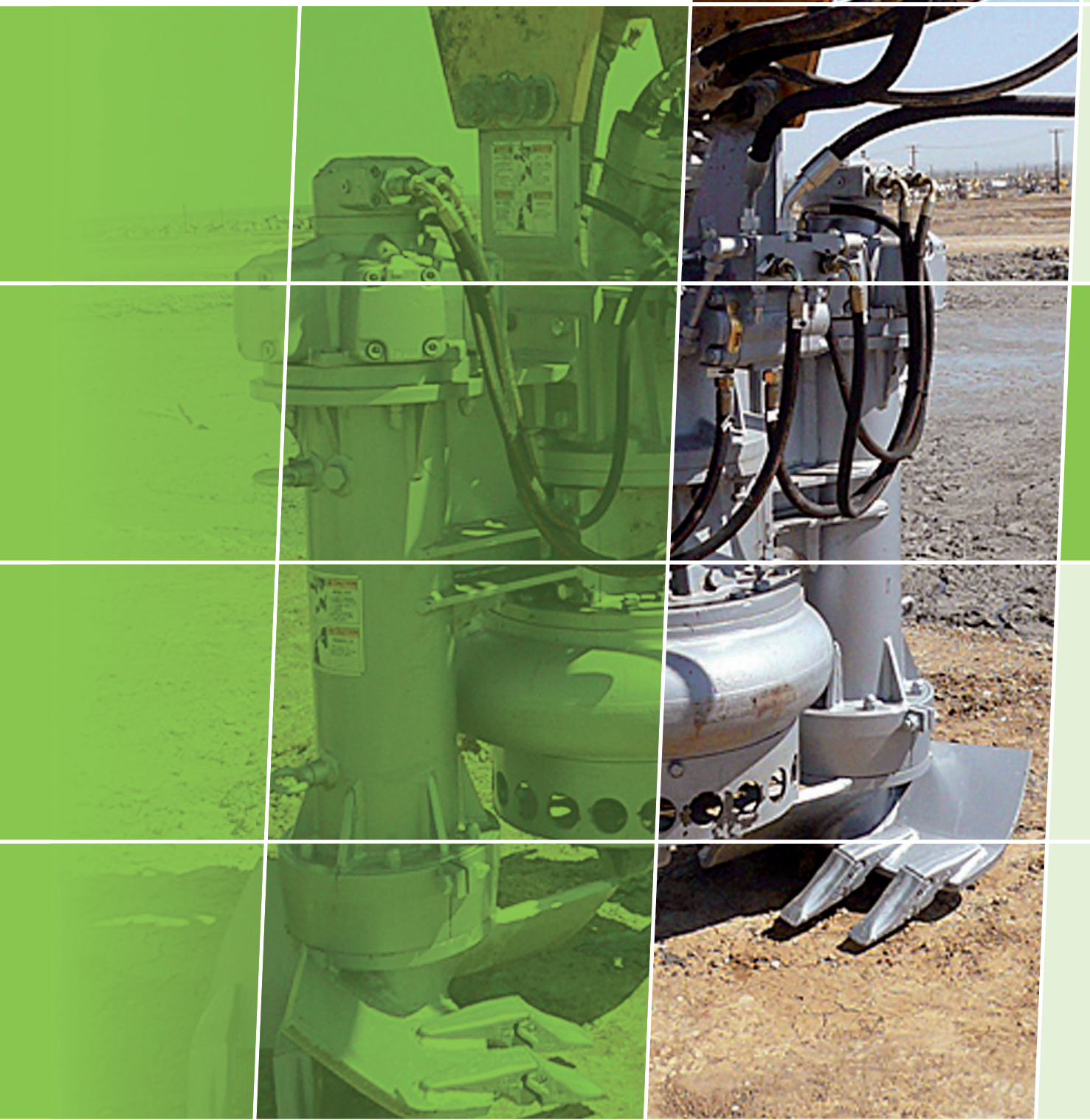

**DRAGFLOW**  
DREDGING • MINING • INDUSTRY

[www.dragflow.it](http://www.dragflow.it)

**Dragflow srl**

Via Pasubio, 40 - 37069 Villafranca (VR) Italy  
tel. +39.045.6304521 - fax +39.045.6335758  
info@dragflow.it - www.dragflow.it

# Hydraulic excavators

## EXHY 20

### TECHNICAL SPECIFICATIONS

Hydraulic motor	Radial piston
R.P.M.	30 / 40 / 50
Power (cont. operation) (HP)	11 / 15 / 18
Power (inter. operation) (HP)	13 / 18 / 22
Capacity (l/min)	22 / 29 / 36
Pressure (cont. operation) (bar)	250
Pressure (inter. operation) (bar)	300
Torque (cont. operation) (kgm)	260 / 261 / 262
Torque (inter. operation) (kgm)	311 / 313 / 314
Oil specifications	Viscosity 33 mm/s (4.5 °E)
Fixture IN/OUT (BSP)	1 1/4"
Drainage (BSP)	3/8"
Weight (kg)	500



### PERFORMANCE CURVE

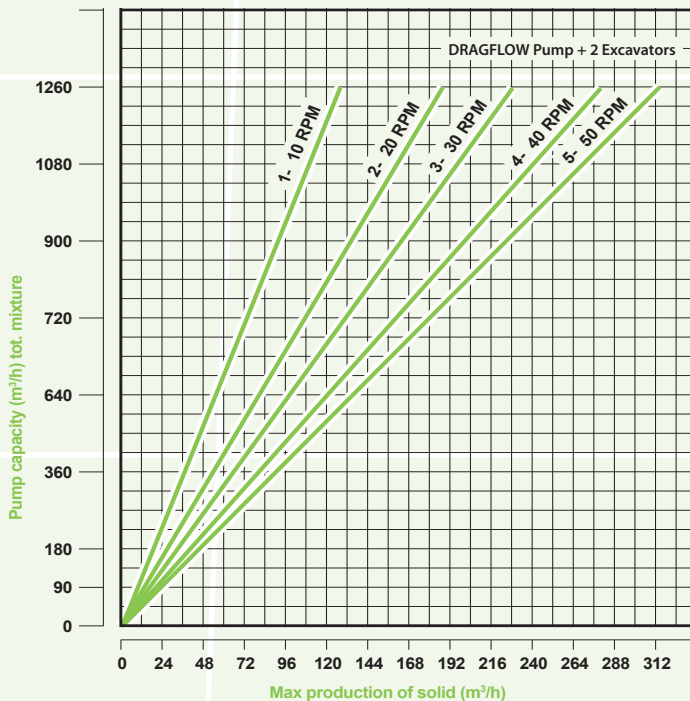

### MATERIALS COMPACTED HARD SAND

	EXCAVATORS (RPM)	% OF SOLID
1	10	10 %
2	20	15 %
3	30	18 %
4	40	22,2 %
5	50	25 %

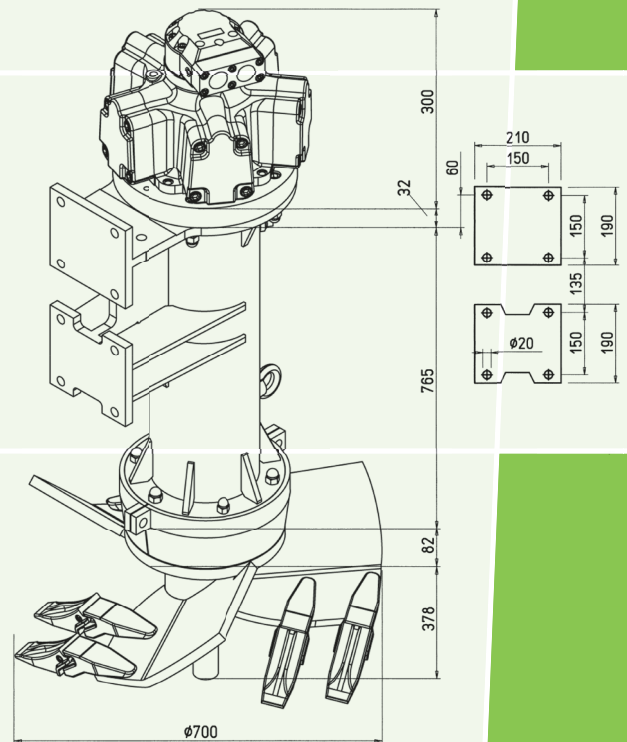

**DRAGFLOW**  
DREDGING • MINING • INDUSTRY

www.dragflow.it